

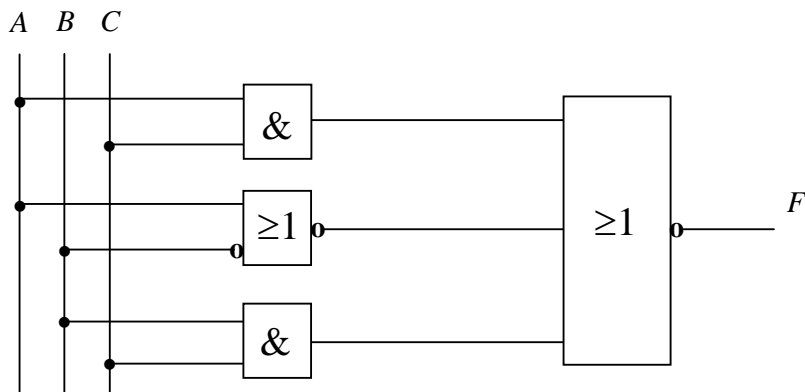

Dugga 2: Boolesk algebra och kombinatoriska nät
Quiz 2: Boolean algebra and combinational circuits

1.



- a) Ange det logiska uttrycket för F och ställ upp en funktionstabell.
- b) Förenkla det logiska uttrycket för F . Rita det förenklade grindnätet.
- a) Give the expression for F and make a function table.
- b) Simplify the expression for F . Draw the simplified combinational circuit.

(6 p)

2. Konstruera ett kombinatoriskt nät med valfria grindar¹ som fungerar enligt vidstående sanningstabell. Nätet skall vara så litet som möjligt.

Realize a combinational circuit with optional gates¹ according to the truth table besides. The circuit must be as small as possible.

(4 p)

A	B	C	D	E	F
0	0	0	0	0	1
0	0	0	0	1	0
0	0	0	1	0	1
0	0	0	1	1	0
0	0	1	0	0	0
0	0	1	0	1	1
0	0	1	1	0	0
0	0	1	1	1	1
0	1	0	0	0	1
0	1	0	0	1	0
0	1	0	1	0	1
0	1	0	1	1	0
0	1	1	0	0	0
0	1	1	0	1	1
0	1	1	1	0	0
0	1	1	1	1	1
1	0	0	0	0	1
1	0	0	0	1	1
1	0	0	1	0	1
1	0	0	1	1	1
1	0	1	0	0	0
1	0	1	0	1	1
1	0	1	1	0	0
1	0	1	1	1	1
1	1	0	0	0	1
1	1	0	0	1	1
1	1	0	1	0	1
1	1	0	1	1	1
1	1	1	0	0	0
1	1	1	0	1	1
1	1	1	1	0	0
1	1	1	1	1	1

¹ AND, NAND, OR, NOR, EXOR, EXNOR & INVERTERS

$$x + x = x$$

$$x \cdot x = x$$

$$x + \bar{x} = 1$$

$$x \cdot \bar{x} = 0$$

$$x + 1 = 1$$

$$x \cdot 0 = 0$$

$$x + 0 = x$$

$$x \cdot 1 = x$$

$$\bar{\bar{x}} = x$$

$$x + (y + z) = (x + y) + z$$

$$x(yz) = (xy)z$$

$$x + y = y + x$$

$$xy = yx$$

$$x(y + z) = xy + xz$$

$$x + yz = (x + y)(x + z)$$

$$x + xy = x$$

$$x(x + y) = x$$

$$xy + \bar{x}z = xy + \bar{x}z + yz$$

$$(x + y)(\bar{x} + z) = (x + y)(\bar{x} + z)(y + z)$$

$$\overline{(x + y)} = \bar{x} \cdot \bar{y}$$

$$\overline{(xy)} = \bar{x} + \bar{y}$$

Associativ
Associativ

Kommutativ
Kommutativ

Distributiv
Distributiv

Absorbtion
Absorbtion

Consensus
Consensus

De Morgan
De Morgan

Benämning	Funktion	Sannings- tabell	SYMBOL																
			Europeisk IEC 117-15	Ameritansk															
INVERTE- RARE	$Y = \bar{A}$	<table border="1"> <tr><td>A</td><td>Y</td></tr> <tr><td>0</td><td>1</td></tr> <tr><td>1</td><td>0</td></tr> </table>	A	Y	0	1	1	0											
A	Y																		
0	1																		
1	0																		
AND	$Y = A \cdot B$	<table border="1"> <tr><td>A</td><td>B</td><td>Y</td></tr> <tr><td>0</td><td>0</td><td>0</td></tr> <tr><td>0</td><td>1</td><td>0</td></tr> <tr><td>1</td><td>0</td><td>0</td></tr> <tr><td>1</td><td>1</td><td>1</td></tr> </table>	A	B	Y	0	0	0	0	1	0	1	0	0	1	1	1		
A	B	Y																	
0	0	0																	
0	1	0																	
1	0	0																	
1	1	1																	
OR	$Y = A + B$	<table border="1"> <tr><td>A</td><td>B</td><td>Y</td></tr> <tr><td>0</td><td>0</td><td>0</td></tr> <tr><td>0</td><td>1</td><td>1</td></tr> <tr><td>1</td><td>0</td><td>1</td></tr> <tr><td>1</td><td>1</td><td>1</td></tr> </table>	A	B	Y	0	0	0	0	1	1	1	0	1	1	1	1		
A	B	Y																	
0	0	0																	
0	1	1																	
1	0	1																	
1	1	1																	
NAND	$Y = \overline{A \cdot B}$	<table border="1"> <tr><td>A</td><td>B</td><td>Y</td></tr> <tr><td>0</td><td>0</td><td>1</td></tr> <tr><td>0</td><td>1</td><td>1</td></tr> <tr><td>1</td><td>0</td><td>1</td></tr> <tr><td>1</td><td>1</td><td>0</td></tr> </table>	A	B	Y	0	0	1	0	1	1	1	0	1	1	1	0		
A	B	Y																	
0	0	1																	
0	1	1																	
1	0	1																	
1	1	0																	
NOR	$Y = \overline{A + B}$	<table border="1"> <tr><td>A</td><td>B</td><td>Y</td></tr> <tr><td>0</td><td>0</td><td>1</td></tr> <tr><td>0</td><td>1</td><td>0</td></tr> <tr><td>1</td><td>0</td><td>0</td></tr> <tr><td>1</td><td>1</td><td>0</td></tr> </table>	A	B	Y	0	0	1	0	1	0	1	0	0	1	1	0		
A	B	Y																	
0	0	1																	
0	1	0																	
1	0	0																	
1	1	0																	
EX OR	$Y = A \oplus B$	<table border="1"> <tr><td>A</td><td>B</td><td>Y</td></tr> <tr><td>0</td><td>0</td><td>0</td></tr> <tr><td>0</td><td>1</td><td>1</td></tr> <tr><td>1</td><td>0</td><td>1</td></tr> <tr><td>1</td><td>1</td><td>0</td></tr> </table>	A	B	Y	0	0	0	0	1	1	1	0	1	1	1	0		
A	B	Y																	
0	0	0																	
0	1	1																	
1	0	1																	
1	1	0																	